

Fill_xr Sensor



Fill_xr Sensor

X-ray sensor for fill level inspection.

X-Ray Sensor for Fill Level Inspection

The TapTone Fill_xr sensor uses low energy X-ray technology to inspect steel, aluminum, plastic and glass containers for proper fill level. The system can be configured to detect underfilled and overfilled containers. The sensor mounts on a remote variable height stand and requires no modifications to the existing production conveyor. The Fill_xr sensor is compatible with the TapTone T550, T4000 HMI and PC, and PRO Series user interfaces and can be added to existing TapTone systems as an optional inspection.

Benefits

- Detects overflow and underfill inspection on one sensor.
- Accurate fill level inspection at production line speeds.
- Cantilever design requires no line modifications.
- No tools required for change-overs
- Simple height adjustment

Applications

- Steel or Aluminum beverage containers
- Food cans
- Carbonated and LN2 dosed beverages
- Household chemicals
- Nutraceutical products
- Personal care & cosmetics

How It Works

X-ray technology is used to measure the product fill level in steel, aluminum, glass, plastic and paper containers. An X-ray tube energized at high voltage is used to produce a low energy X-ray beam. This X-ray beam is focused to look through the container in the expected fill level region. As the X-ray beam penetrates the container, it is attenuated by the amount of product blocking the beam. The beam is monitored by a scintillation detector, which counts the X-ray intensity after it goes through the container. The level of intensity is proportionate to the fill level of the container. User set rejection limits defines the high or low fill threshold.



Full container (left), underfilled container (right).

SYSTEM SPECIFICATIONS

General Specifications

Operating Speed (max)	2,000 containers per minute
Maximum Container Width	165 mm (6.5 in) trigger dependent
Compatible with	T500, T4000 systems
Power Requirements	Voltage: 10-30 VDC (Typical 24 VDC) Current: 340mA maximum
Operating Conditions	Stable Ambient Temperature: 0° - 50° C (32° to 122° F)
Weight	20.5 kg (45 lbs)
Max Range from OF to UF	25.4 mm (1 in)
Trigger Sensor	10-30 VDC, PNP Sourcing Output
Measurement Resolution	.5 mm (0.019 in) application dependent
X-ray Transmitter	X-Ray tube, 35-60kv, 10-30 μ A
X-ray Detector	0-10VDC Analog output

Material & Interface Enclosure

Environmental Rating	NEMA 4X, IP67
Construction	Box: 304 electro polished, stainless steel housing, high pressure wash-down
Mounting	Angled pedestal stand, 304 stainless steel, tripod base, adjustable height range 241 mm (9.5 in)



49 Edgerton Drive • North Falmouth, MA 02556 USA

P: +1 508.563.1000

F: +1 508.564.9945

E-Mail: taptone@teledyne.com

8/2011. Specifications subject to change without notice.
TAPTONE is a registered trademark of Teledyne Instruments, Inc. Copyright 2013, TELEDYNE TAPTONE.

Fill_xr Sensor

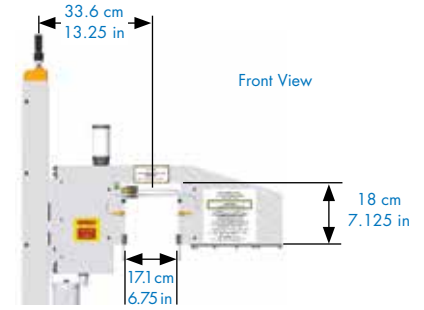

Fill_xr Sensor | Compatible Systems

- T550
- T4000 HMI and PC
- PRO Series

The Fill_xr Sensor can also be added to existing systems as an upgrade. Sensor requires TapTone user interface for operation.

www.TapTone.com