



T500

On-line, production speed inspection for leaks, vacuum, pressure, physical defects, and fill level on rigid and flexible containers.

Simplified Control / Versatile Inspection

The TapTone 500 provides complete inspection of containers for fill level, pressure and vacuum, and physical defects. When connected with TapTone PC Software, this value-packed combination provides an unbeatable system for fast product setup, ease of use, timely data collection and reject tracking. The TapTone 500 is a cost effective solution for inspection of your plastic, metal and glass containers.

Benefits

- Rapid on-line inspection: up to 2,000 containers per minute
- Combined inspections on a single controller: up to 3 primary inspections (Acoustic, Proximity, and X-ray)
- Up to 7 digital inputs
- Two independent reject outputs for container sorting
- Floor and conveyor mount options for sensors

Applications

- Vacuum inspection on metal cans with sanitary or pull tab ends
- Vacuum inspection on glass jars with lug caps or pop button ends
- Vacuum inspection on plastic containers with composite closures
- Pressure inspection on carbonated or LN2 dosed beverage cans
- Leak inspection on glass beer bottles with metal crowns
- Fill height inspection on glass, metal and plastic containers
- Flat sour detection
- Cooker protection

How It Works

Acoustic Technology

Acoustic technology measures pressure or vacuum in containers with metal closures that do not have a measurable lid deflection. The sensor applies a "tap" to the top of each container lid using an electromagnetic pulse, exciting the closure. The lid vibrates at a natural resonant frequency "tone" based on internal pressure or vacuum. The resultant "tone" signal is sensed by a microphone. The Digital Signal Processor (DSP) produces a real-time signal spectrum and calculates the frequency of the "tone" for that lid which is then compared to user set limits. Containers with a frequency outside these limits are rejected.

Proximity Technology

Proximity technology measures pressure or vacuum in containers with metal closures by measuring the lid deflection. The sensor produces a continuous magnetic field that monitors the distance between the sensor and the metal lid. The continuous signal is digitally sampled to produce a merit value of the lid profile. The profile value is then compared to user set limits. Containers with lid deflection outside these limits are rejected.

Fill Level Technology

Optical Technology: The Optical sensor is used to measure fill level of water based products in glass and plastic containers. The sensor utilizes a special emitter/receiver infrared wavelength tuned to the absorption band of water. The beam is powerful enough to pass through most types of plastic and glass containers but will not pass through water based liquids.

X-ray Technology: The X-ray sensor is used to measure the fill level in steel, aluminum, glass, plastic and paper containers. An x-ray beam is focused in the expected fill level region of the container. As the x-ray beam penetrates the container, it is attenuated by the amount of product blocking the beam. The attenuation is proportionate to the fill level of the container.

SYSTEM SPECIFICATIONS

General Specifications

Operating Speed	2,000 containers/min maximum (Proximity, X-ray, Digital Inputs) 1,500 containers/min maximum (Acoustic)
Digital Outputs	1-6
Digital Inputs	1-7
Shaft Encoder	Aluminum
AC Line Voltage	115–230 VAC ± 10%, 50–60 Hz, 1-phase, 300 watts, 15 amp
Reject Outputs	2
Operating Temperature	0° to 50°C (32° to 122°F)
Humidity	0 to 90%, non-condensing
Altitude	Sea level to 3,035m (10,000 feet)

Material & Control Enclosure

Enclosure Environmental Rating	Stainless steel, NEMA 4X, IP65 rated
Wash Down	Low-pressure water
Human Interface	LCD 240 x 128 pixels, back-lit

Software & Networking Capabilities

Supports Multiple Languages
Stores Multiple Product Set-Ups
RS-232 Serial Interface Port
Password Protection

TapTone 500

T500

Control Enclosure

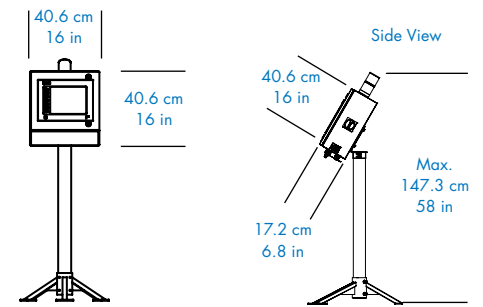

Optional sensor mountings

(Acoustic, Proximity)

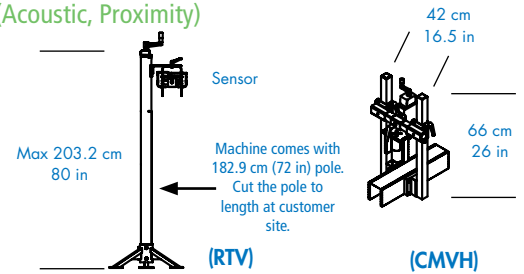

T500 | System Options

Acoustic Test Bottle: The test bottle provides a predetermined acoustic signal to benchmark the machine's performance. Designed for steel crown and ROPP closure applications.

Cap Inspection: Sensors for missing, high, or cocked cap detection can be added as an option. Both optical and camera systems are available.

Proximity Test Can: The proximity test can provides a repeatable curvature for gauging the performance of the proximity sensor. Designed for beverage can applications.

Rejectors: TapTone offers a line of pneumatic ram and standing rejection systems.

Reject Verification: Detects a container that has failed the inspection but has not been rejected from the production conveyor.



TELEDYNE TAPTONE
Package Inspection Systems
A Teledyne Technologies Company

49 Edgerton Drive • North Falmouth, MA 02556 USA

P: +1 508.563.1000

F: +1 508.564.9945

E-Mail: taptone@teledyne.com

7/2010. Specifications subject to change without notice.
TAPTONE is a registered trademark of TELEDYNE BENTHOS, INC. Copyright 2010, TELEDYNE TAPTONE.

www.TapTone.com