



Compact Container Inspection System

The TapTone 100 on-line inspection system incorporates various sensors for detecting defects in cans, bottles and jars. The system has a simple design and is extremely cost effective. A single conveyor mount configuration houses the control electronics and plug-in connectors to accommodate up to seven different inspections. The "all-in-one" design requires minimal line space and no floor space, which is especially important for crowded production lines. A menu driven keypad with 6 keys provides a simple-to-use interface. Self-diagnostics are utilized for continuous monitoring of machine performance.

T100

On-line, production speed inspection for low vacuum, swelled cans, button-up lids, physical defects, and fill level on rigid and flexible containers.

Benefits

- Rapid on-line inspection: up to 2,000 containers per minute
- Menu-driven keypad
- 6 digital inputs
- 4 optional outputs
- Remote rejector option
- Shaft encoder for variable speed lines

Applications

- Vacuum inspection on metal cans with sanitary ends
- Vacuum inspection on glass jars with lug caps or pop button ends
- Missing label inspection
- Cap and closure inspection
- Missing tamper band detection
- Missing foil seals
- Fill level inspection in glass or plastic containers (application specific)

How It Works

Proximity Technology

Proximity technology measures pressure or vacuum in containers with metal closures by measuring the lid deflection. The sensor produces a continuous magnetic field that monitors the distance between the sensor and the metal lid. The continuous signal is digitally sampled to produce a merit value of the lid profile. The profile value is then compared to user set limits. Containers with lid deflection outside these limits are rejected.

Fill Level Technology

Optical Technology: The Optical sensor is used to measure fill level of water based products in glass and plastic containers. The sensor utilizes a special emitter/receiver infrared wavelength tuned to the absorption band of water. The beam is powerful enough to pass through most types of plastic and glass containers but will not pass through water based liquids.

SYSTEM SPECIFICATIONS

General Specifications

Operating Speed	Up to 2,000 containers/min
Digital Outputs	1-4
Digital Inputs	1-6
Shaft Encoder	Aluminum
AC Line Voltage	115–240 VAC ± 10%, 50–60 Hz, 1-phase, 250 watts
Reject Outputs	1
Operating Temperature	0° to 50° C (32° to 122° F)
Humidity	0 to 90%, non-condensing
Altitude	Sea level to 3,035m (10,000 feet)

Material & Control Enclosure

Enclosure Environmental Rating	Stainless steel, NEMA 4X, IP65 rated
Wash Down	Low-pressure water
Mounting	Conveyor mount (standard), RTV pole mount (optional)
Human Interface	LCD 4 x 20 character, back-lit

Software & Network Capabilities

Stores Multiple Product Set-Ups
Flash Memory for Easy Upgrades
RS-232 Serial Interface Port
Self Diagnostics for Troubleshooting



49 Edgerton Drive • North Falmouth, MA 02556 USA

P: +1 508.563.1000

F: +1 508.564.9945

E-Mail: taptone@teledyne.com

7/2010. Specifications subject to change without notice.
TAPTONE is a registered trademark of TELEDYNE BENTHOS, INC. Copyright 2010, TELEDYNE TAPTONE.

T100

Control Enclosure

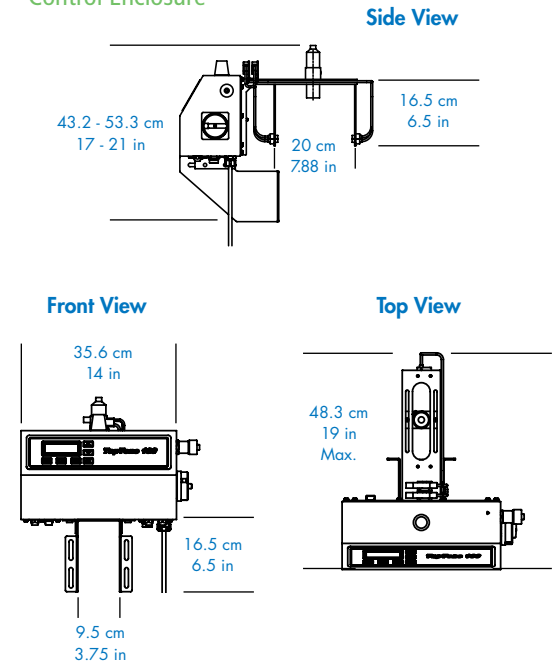

Optional sensor mountings

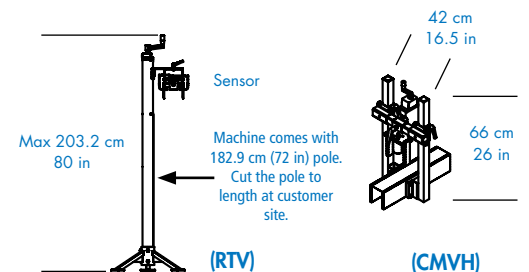

T100 | System Options

Cap Inspection: Sensors for missing, high, or cocked cap detection can be added as an option. Both optical and camera systems are available.

Rejectors: TapTone offers a line of pneumatic ram and standing rejection systems.

Reject Verification: Detects a container that has failed the inspection but has not been rejected from the production conveyor.

www.TapTone.com