



T4000-FS

Stainless steel construction and reinforced side plates make the T4000-FS the ideal system for high pressure and high speed applications.

Pressure Inspection up to 11 bar or 160 psi

The TapTone 4000-FS is designed to handle the higher pressure applications found with many aerosol containers and heavy duty aluminum can/bottle applications. The system inspects 100% of containers at production line speeds. The TapTone 4000-FS is manufactured with a stainless steel transport system for harsh environments. The reinforced side plates give extra rigidity for high pressure applications and allow for a stable reading with excellent resolution. The system can alternatively be fit with a mid-range or low range pressure sensor for applications that require all-stainless steel construction.

Benefits

- Rapid on-line inspection: up to 2.67 m/sec (525 ft/min) maximum
- Easy operation & product set-up using a large color touch screen and icon driven menus
- Controlled access to system features with multi-level passwords
- Combined inspections on a single controller: run up to 4 primary inspections
- Reject and sort with 2 independently operated reject outputs
- Meets CE requirements
- UL and CUL approved

Applications

- Pressure/Leak inspection in aerosol cans with gas propellents
- Pressure inspection in aerosol cans with liquid propellant
- Pressure/Leak inspection in carbonated or LN2 dosed plastic containers
- Pressure/Leak inspection in carbonated or LN2 dosed beverage cans
- Pressure/Leak inspection in LN2 dosed retorted dairy based drinks
- Pressure/Leak inspection in containers with internal pressure up to 11 bar or 160 psi

How It Works

Force Technology

Detects leaks and low pressure in LN2 dosed containers, carbonated beverage containers and aerosol containers. Parallel belts transport the container past a sensor that measures the tension on the sidewall of the container. This action allows the system to measure the pressure inside the container. Utilizing DSP technology, the controller analyzes the measurement and assigns a merit value to each container. If the merit value is outside of the acceptable range, a reject signal activates a remote reject system and the container is removed from the line.

Fill Level Technology

Optical Technology: The Optical sensor is used to measure fill level of water based products in glass and plastic containers. The sensor utilizes a special emitter/receiver infrared wavelength tuned to the absorption band of water. The beam is powerful enough to pass through most types of plastic and glass containers but will not pass through water based liquids.

X-ray Technology: The X-ray sensor is used to measure the fill level in steel, aluminum, glass, plastic and paper containers. An x-ray beam is focused in the expected fill level region of the container. As the x-ray beam penetrates the container, it is attenuated by the amount of product blocking the beam. The attenuation is proportionate to the fill level of the container.

SYSTEM SPECIFICATIONS

General Specifications

| | |
|--|------------------------------------|
| Pressure Measurement Range | Up to 11 bar (160 psi) |
| Operating Speed (max) | 2.67 m/sec (525 ft/min) |
| Standard Conveyor Height Range | 91.4 cm-132 cm (36 in-52 in) |
| Optional Conveyor Height (leg extensions) | 121.9 cm-162.5 cm (48 in-64 in) |
| Belt Opening (maximum) | 159 mm (6.25 in) |
| Digital Outputs | 8 |
| Digital Inputs | 4 |
| Shaft Encoder | Stainless Steel |
| AC Line Voltage (standard) | 230 VAC, 1-phase |
| AC Line Voltage (option) | 460 VAC, 3-phase |
| Alarm Outputs | 2 (multi-function configurable) |
| Reject Outputs | 2 |

TapTone 4000-FS

Material & Control Enclosure

| | |
|--------------------------------|--------------------------------------|
| Enclosure Environmental Rating | Stainless steel, NEMA 4X, IP65 rated |
| Transport Deck Materials | 304 Stainless steel |
| Frame Material Finish | Stainless steel |
| Touch Screen Display | 25.4 cm (10 in) color HMI |

Software & Networking Capabilities

- Remote Diagnostics
- Supports Multiple Languages
- Stores Multiple Product Set-Ups
- Supports Industrial Ethernet Protocols (EtherNet/IP and Modbus TCP)
- Multi-Level Password Protection



49 Edgerton Drive • North Falmouth, MA 02556 USA

P: +1 508.563.1000

F: +1 508.564.9945

E-Mail: taptone@teledyne.com

7/2010. Specifications subject to change without notice.
TAPTONE is a registered trademark of TELEDYNE BENTHOS, INC. Copyright 2010, TELEDYNE TAPTONE.

T4000-FS

Control Enclosure

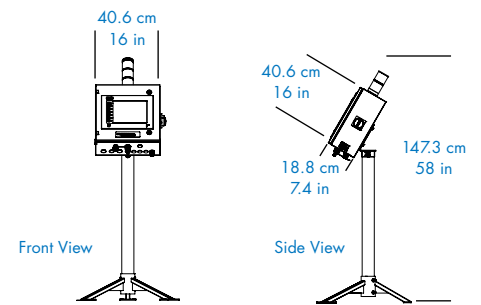

T4000-FS

Sensor

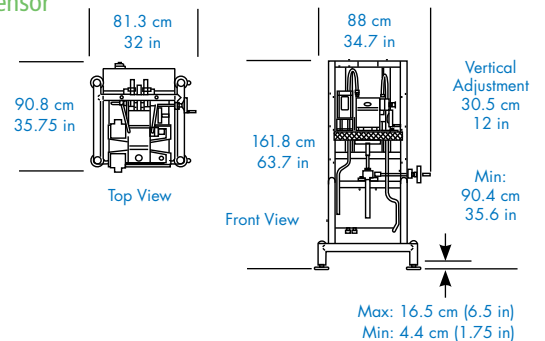

T4000 FS | System Options

Air Pressure Monitoring: Monitors and displays the air pressure at the rejector. Alarm signal will activate if the air pressure drops below user pre-set limits.

Belt Wash: The belt wash system is designed to clean and dry the compression belts on the T4000.

Cap Inspection: Inspection sensors for missing, high, or cocked cap detection. Both optical and camera systems are available.

Rejectors: TapTone offers a line of pneumatic ram and standing rejection systems.

Reject Verification: Detects a container that has failed the inspection but has not been rejected from the production conveyor.

Trigger Blow-Off: Keeps the lens of the photo triggers clean. Suggested for use in harsh environments.

www.TapTone.com