



## T4000-DSC

Dual Sensor Compression Inspection for leaks, fill level, and physical defects on flexible plastic containers. Available in Standard or Low Profile configuration.

## Advanced Leak Detection for Flexible Containers

The TapTone 4000-Dual Sensor Compression (DSC) system is designed to inspect a wide variety of flexible containers for micro leaks. The design incorporates our patented dual sensor technology and high speed compression belts for improved accuracy and container handling. The system was designed for harsh environments. When combined with optional sensors, this system will also perform fill level inspection, cap inspection and label detection.

### Benefits

- Rapid on-line inspection: up to 1.52 m/sec (300 ft/min) maximum
- Accurate leak detection as small as 0.152 mm (0.006 in). Application & container dependent
- Easy operation & product set-up using a large color touch screen and icon driven menus
- Combined inspections on a single controller: Up to 4 primary inspections (Dual Compression, X-ray, Laser, Acoustic, Proximity)
- Reject and sort with 2 independently operated reject outputs
- Meets CE requirements, UL and CUL approved
- Available in a Low Profile format for small containers

### Applications

- Leak detection in plastic containers
- Leak detection in food/dairy cups
- Leak detection in hot filled plastic containers
- Leak detection in stand up pouches
- Leak detection in tubes
- Leak detection in blow/fill seal vials
- Leak detection in single serve size trays and tubs

## How It Works

### Dual Sensor Compression Technology

Detects and rejects leaking and damaged flexible containers at production line speeds up to 1.52 m/sec (300 ft/min). The system is designed with dual parallel belts suspended over the customer's existing conveying system. As the container passes through the system, the dual parallel belts apply force to the sidewall of the container. This action compresses the headspace of the container which allows a comparative measurement to be taken at both the infeed and the discharge of the system. Comparing readings on the same container at the infeed and discharge of the system eliminates the effects of typical product and container variations.



▲ TapTone T4000-DSC Standard Profile



▲ TapTone T4000-DSC-LP Low Profile

# SYSTEM SPECIFICATIONS

## General Specifications

## T4000-DSC/T4000-DSC-LP

Operating Speed (max)	1.52 m/sec (300 ft/min)
Standard Conveyor Height Range	91.4 cm-132 cm (36 in-52 in)
Optional Conveyor Height (leg extensions)	121.9 cm-162.5 cm (48 in-64 in)
Belt Opening (maximum)	159 mm (6.25 in)
Digital Outputs	8
Digital Inputs	4
Shaft Encoder	Stainless Steel
AC Line Voltage (standard)	230 VAC, 1-phase
AC Line Voltage (option)	460 VAC, 3-phase
Alarm Outputs	2 (multi-function configurable)
Reject Outputs	2

## Material & Control Enclosure

Enclosure Environmental Rating	Stainless steel, NEMA-4X, IP65 rated
Transport Deck Materials	Stainless steel
Frame Material Finish	Stainless steel
Touch Screen Display	25.4 cm (10 in) color HMI

## Software & Networking Capabilities

- Remote Diagnostics
- Supports Multiple Languages
- Stores Multiple Product Set-Ups
- Supports Industrial Ethernet Protocols (EtherNet/IP and Modbus TCP)
- Multi-Level Password Protection



**TELEDYNE TAPTONE**  
Package Inspection Systems  
A Teledyne Technologies Company

49 Edgerton Drive • North Falmouth, MA 02556 USA

P: +1 508.563.1000

F: +1 508.564.9945

E-Mail: [taptone@teledyne.com](mailto:taptone@teledyne.com)

8/2011. Specifications subject to change without notice.  
TAPTONE is a registered trademark of TELEDYNE BENTHOS, INC. Copyright 2010, TELEDYNE TAPTONE.

## T4000-DSC

### Control Enclosure

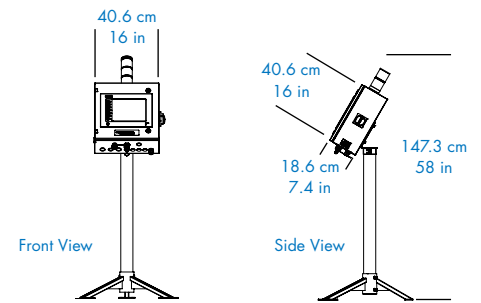

## T4000-DSC

### Sensor

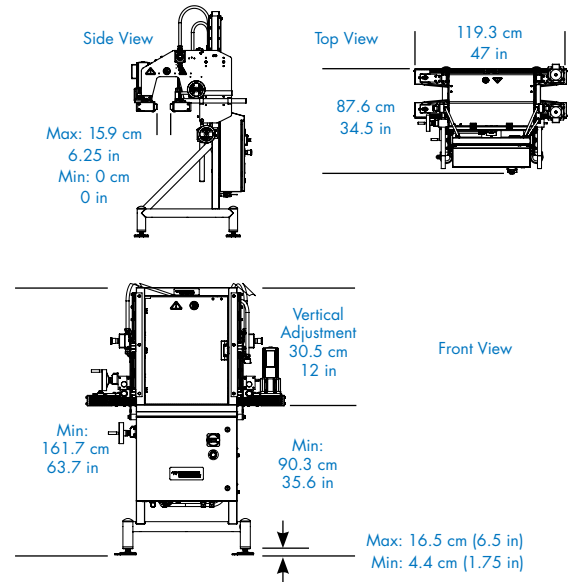

## T4000 DSC | System Options

**Air Pressure Monitoring:** Monitors and displays the air pressure at the rejector. Alarm signal will activate if the air pressure drops below user pre-set limits.

**Belt Wash:** The belt wash system is designed to clean and dry the compression belts on the T4000.

**Cap Inspection:** Inspection sensors for missing, high, or cocked cap detection. Both optical and camera systems are available.

**Down Bottle Inspection:** The Down Bottle Inspection sensors will detect a bottle that has fallen over on the conveyor and was not inspected.

**Rejectors:** TapTone offers a line of pneumatic ram and standing rejection systems.

**Reject Verification:** Detects a container that has failed the inspection but has not been rejected from the production conveyor.

**Trigger Blow-Off:** Keeps the lens of the photo triggers clean. For use in harsh environments.

[www.TapTone.com](http://www.TapTone.com)