



CapVu™

Affordable, high-speed camera sensor for accurate cap and closure inspection

Camera Sensor for Cap and Closure Inspection

The TapTone CapVu camera sensor is designed to perform visual inspection of container closures for missing caps, high caps, cocked or tilted caps, and missing tamper rings. The sensor includes a high speed digital camera and LED back light housed in a stainless steel enclosure. The sensor mounts on a remote variable height stand. The CapVu sensor is compatible with any TapTone control platform and can be added to existing TapTone systems as an optional inspection.

Benefits

- Low-cost camera inspection at production line speeds
- No conveyor modifications required; sensor is cantilevered over existing conveyor
- No tools required for change-overs
- Simple height adjustment
- Easy operation using a color touch screen and icon driven menus
- USB Port to download images
- Container teach-in
- Meets CE requirements

Applications

- Dairy containers
- Hot filled beverages
- Carbonated and LN2 dosed beverages
- Bottled water
- Condiment containers
- Household chemicals
- Nutraceutical products
- Personal care & cosmetics

How It Works

The CapVu sensor uses vision technology to inspect the cap or closure on containers after they have been filled and capped. A good container is passed through the sensor and the image stored in the camera. As the production containers pass through the sensor, the high speed camera takes an image at up to 6000 frames per minute. The image of the production containers are then compared to the image of the good container stored in the camera to determine the proper cap placement. Containers that do not match the good image are rejected. The CapVu sensor can be used to detect missing caps, high caps, cocked or tilted caps, and missing tamper rings on glass, plastic, and metal containers.

Compatible with any TapTone Control Platform!



Good Cap Placement

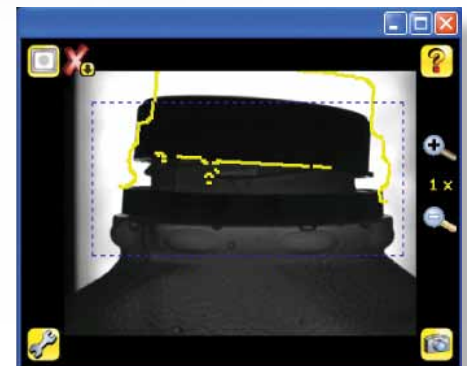

Tilted /Cocked Cap Defect

SYSTEM SPECIFICATIONS

General Specifications

Operating Speed (max)	2,000 containers per minute
Maximum Container Width	170 mm (6.75 in)
Compatible with	T100, T500, T4000 (T1000 as an added option)
Power Requirements	Voltage: 10-30 VDC (Typical 24 VDC) Current: 500mA maximum (exclusive of I/O load)
Operating Conditions	Stable Ambient Temperature: 0° - 50° C (32° to 122° F) Relative Humidity: 0 – 95% maximum, non-condensing
Weight:	9.95 kg (22 lbs)
Trigger Sensor	10-30 VDC, PNP Sourcing Output
Acquisition Time	Frames Per Minute: 6000 max
Light Source	Five high-intensity LEDs, red, diffused acrylic sealed window)
Lamp Connection	4-pin Euro-fast (M12) male socket
Lamp Construction	Housing; nickel-plated aluminum or 316 stainless steel (optional)
Lamp Rating	Nickel-plated model: NEMA 4, IP68
Lamp Useful Life	50,000 hours (5.7 years) LED ON time before 30% output reduction

Material & Control Enclosure

Display	LCD color display with integrated touch screen 68.5 mm (2.7 in). Water tight when sealed cover installed, trans-reflective type
Environmental Rating	Stainless steel, NEMA 4X, IP67 rated
Construction	Box: 304 stainless steel housing
Mounting	Angled pedestal stand, 304 stainless steel, tripod base, adjustable height range 241 mm (9.5 in)

Software & Networking Capabilities

- Password protected (sensor lock)
- USB 2.0 Host 8-pin Euro-fast (M12) female connector Optional Euro to USB cable required for USB thumb drive feature



TELEDYNE TAPTONE
Package Inspection Systems
A Teledyne Technologies Company

49 Edgerton Drive • North Falmouth, MA 02556 USA

P: +1 508.563.1000

F: +1 508.564.9945

E-Mail: taptone@teledyne.com

7/2010. Specifications subject to change without notice.
TAPTONE is a registered trademark of TELEDYNE BENTHOS, INC. Copyright 2010, TELEDYNE TAPTONE.

CapVu Sensor

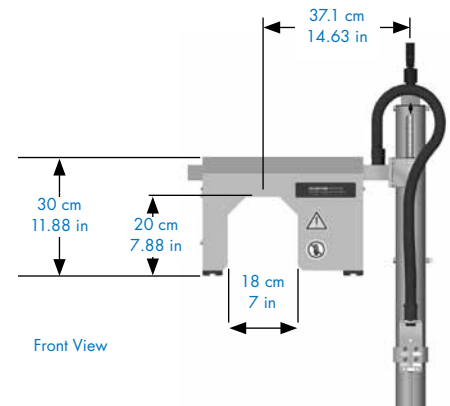

Front View

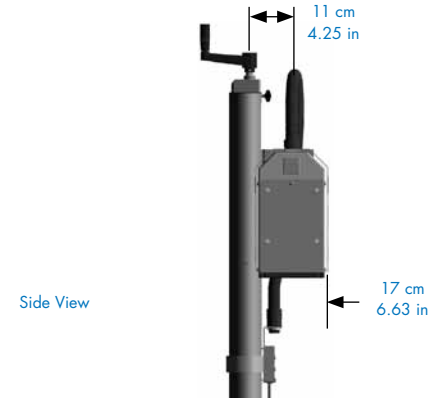

Side View

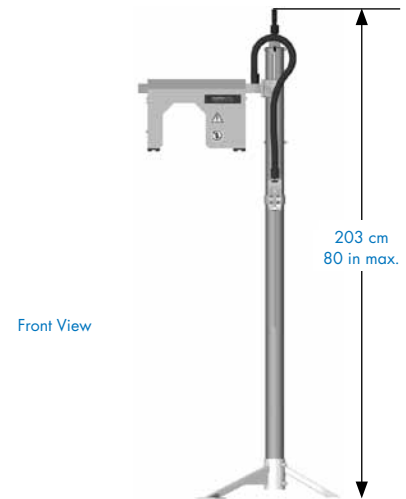

Front View

CapVu Sensor | Compatible Systems

- T100
- T500
- T4000

The CapVu Sensor can also be added to existing systems (including T1000) as an upgrade. Sensor requires TapTone controller for operation.

www.TapTone.com