



TapTone

APPLICATION NOTES

News and information from Teledyne TapTone, a leader in the package inspection industry.

IDENTIFYING LEAKS IN LN2 DOSED ALUMINUM BEVERAGE CANS

Tested: LN2 Dosed Aluminum Beverage Cans

Inspection Desired: The purpose of this test was to find leaks in LN2 dosed aluminum beverage cans using the TapTone 4000-F Force system. Leaks in these containers can cause spoilage in dairy based drinks and compromise the rigidity of the containers themselves. Leaking containers can harm the brand image of upscale beverage products.

The TapTone 4000-F Force Sensor is ideal for finding potential leakers in LN2 dosed or carbonated aluminum beverage containers before they leave the processing plant.

Tested with: TapTone 4000-F Force System



▲ Coffee Drinks - LN2 Dosed Aluminum Cans



▲ Can being tested with the T4000-F

TECHNOLOGY CORNER *HOW IT WORKS*

The TapTone 4000-F Force Sensor utilizes dual parallel belts to transport the container past a load cell that measures the tension on the sidewall of the container. This action allows the system to measure the pressure inside the container. Utilizing DSP technology, the controller analyzes the measurement and assigns a merit value to each container. If the merit value is outside of the acceptable range, a reject signal activates a remote reject system.

T-4000 Controller and Force Sensor. ▶ Sensor has a cantilever design that suspends over the existing conveyor.



TEST SUMMARY

Two different product sizes were supplied for this evaluation. All cans contained a coffee based product and were LN2 dosed. To establish a base line for good containers, 6 pressurized samples were tested two times each. This process generated data points from which an average was calculated. The average merit value* reading for good, pressurized containers was 377.

A low pressure container was made by releasing the internal pressure of one of the samples. The low pressure sample was run four times, alternating with a good container. An average merit value for the container with the loss of pressure was calculated. The average merit value for a low pressure container was 100, (277 merit values less than the average pressurized sample).



Iced Coffee Cans - 11 oz

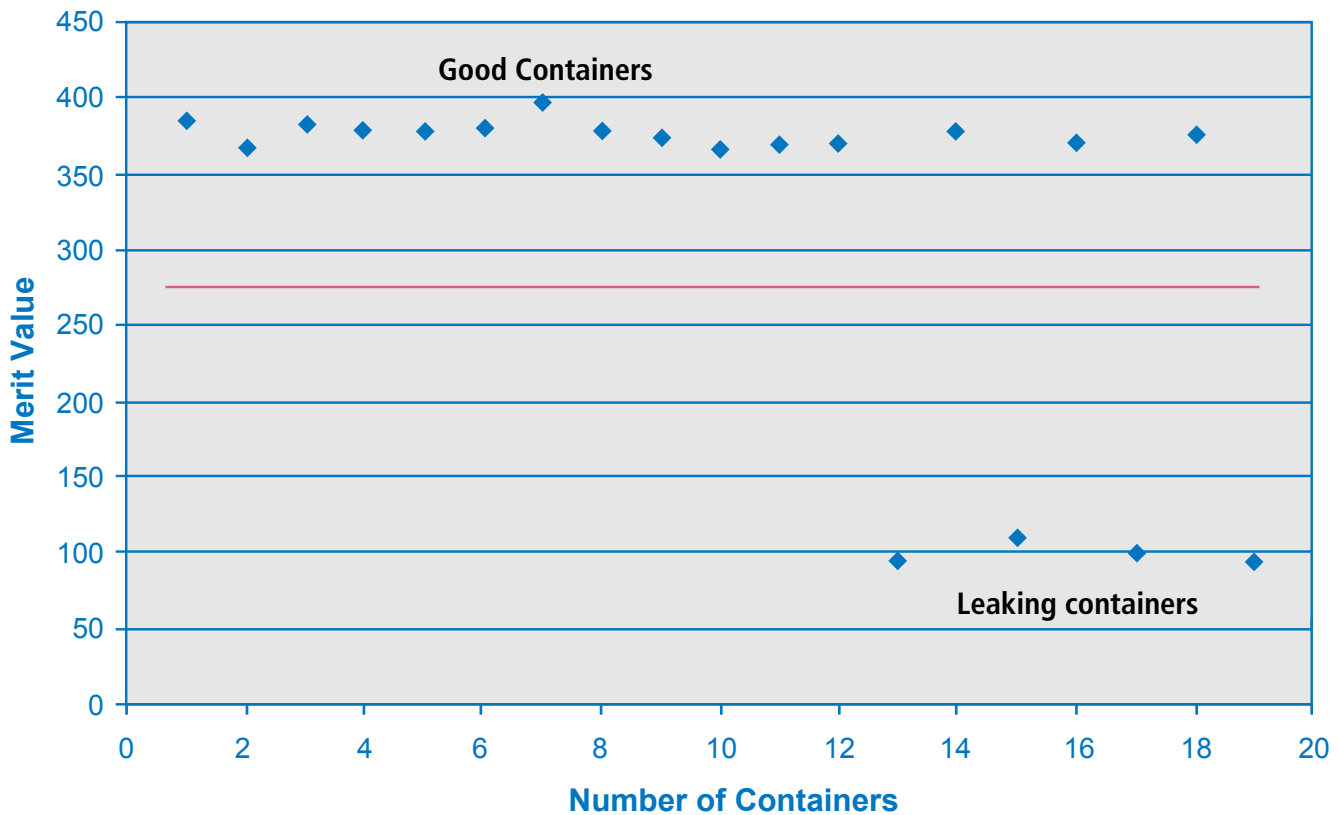

*Merit value is a calculated number determined using an algorithm to compute a resultant from a set of data values.

Note: Containers were evaluated at room temperature.

CONCLUSION

The test data shows that the TapTone Force system can clearly differentiate between a good, pressurized container and a container with low pressure.

Note - The test above did not quantify the pressure sensitivity of the Force system. Data from similar applications has shown that pressure resolution through the sidewall of aluminum cans can be measured in 2 psi increments on cans with internal pressures ranging from 0-17 psi. Pressure sensitivity measured through the can sidewall will normally decrease as the internal can pressure exceeds 17 psi.

Contact Teledyne TapTone or your Local Representative for more information about our Force system and alternate applications. The TapTone 4000 Force system is designed to detect micro leaks and pressure in LN2 dosed and carbonated beverage containers. When combined with an optional X-ray sensor, the system can also perform fill level inspection.

OTHER FORCE APPLICATIONS



◀ LN2 Dosed PET Bottles (water, etc.)

LN2 Dosed Aluminum Bottles ▶



◀ LN2 Dosed Tea or Juice Hot Filled



APPLICATION NOTES

LN2 Dosed:

- Dairy Based Products
- Cans Containing Non-Carbonated Beverages
- Tea or Juice - Hot Filled
- PET Beverage Bottles (water, etc.)

Cans of Dairy Based products are retorted. After retort, the can end could have memory, leaving the end domed, even though the pressure has escaped. By using Force technology on the sidewall of the can, immediately after the retorter, slight differences in pressure are easily detected.

Note: A proximity sensor is also beneficial in this application. The proximity sensor can be utilized in two locations. After the seamer, the proximity sensor will be able to detect low or missing pressure in the cans prior to being retorted. After the retorter (typically combined with the Force system using the same controller) the proximity sensor will detect buckled cans.

Hot Filled Juices and Teas will benefit from the Force System being placed immediately after the seamer. At this point the can end can be domed due to pressure from the hot product regardless of the presence of LN2. By using Force technology on the sidewall of the can, slight differences in pressure are easily detected. A Force system can also be set-up with a consecutive reject alarm to alert an operator if multiple containers are rejected. This could indicate a problem with the LN2 doser.

TapTone 4000-F Force System Controller and Sensor Dimensions

Control Enclosure

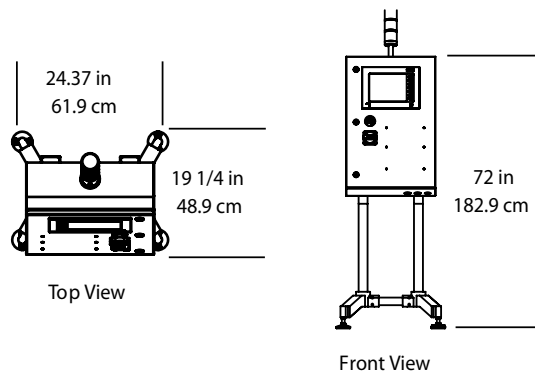

Force

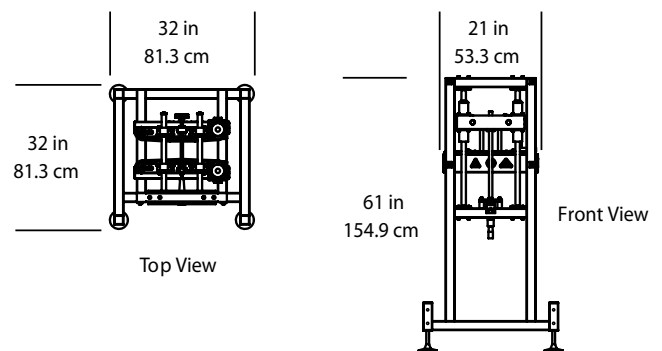

49 Edgerton Drive • North Falmouth, MA 02556 USA

P: +1 508.563.1000 F: +1 508.564.9945 E-Mail: taptone@teledyne.com

10/17/11. Specifications subject to change without notice.

TapTone is a registered trademark of Teledyne TapTone. Copyright 2011, Teledyne TapTone.

